



EV BLOCKS.COM[®]

STANDARD EV BLOCK
INSTALLATION GUIDE



GETTING STARTED

Installation Bill of Materials (EV Block Only)

- 1 - Precast Concrete EV Block Foundation
- 1 - Composite Adaptor Plate
- 4 - 1/2" - 13 x 3" (or M12-2.5 x 75mm) SS Tamper-Resistant Bolt
- 4 - 1/2" (or M12) SS Flat Washer

Prior to beginning construction

1. Verify the locations of any utilities and existing structures prior to starting and excavation.
2. Examine the project site and evaluate the condition of the locations in which the EV Block units will be installed. Notify the proper supervising authority in writing of any conditions that may interfere with the proper installation of the EV Block units or delay completion.
3. Be sure to refer to local building Codes and ensure compliance with any and all local regulations.

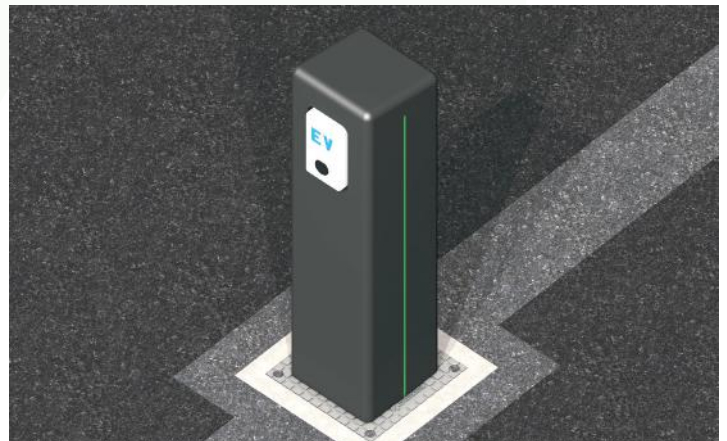
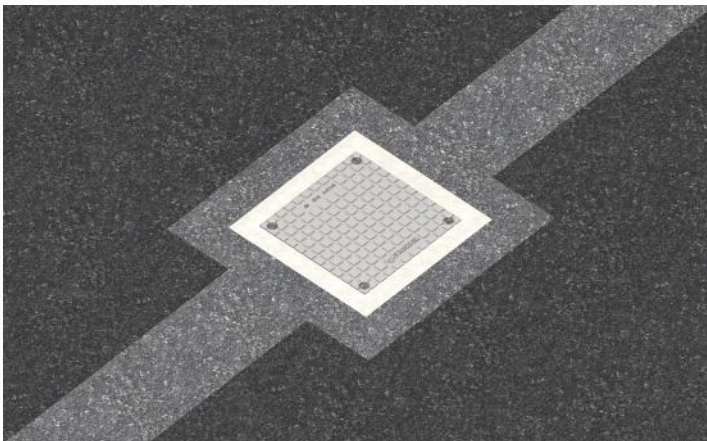
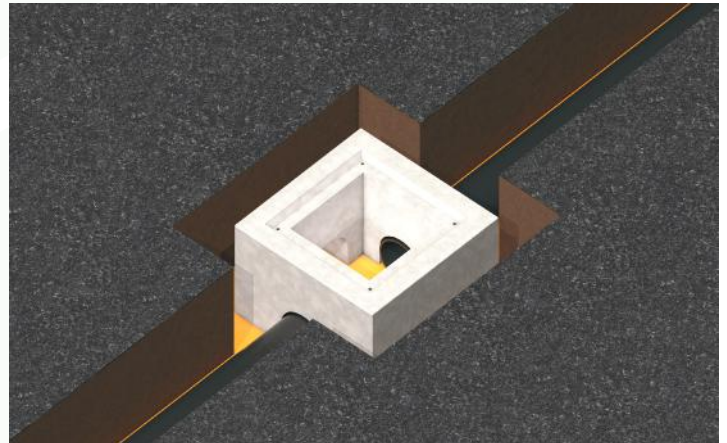
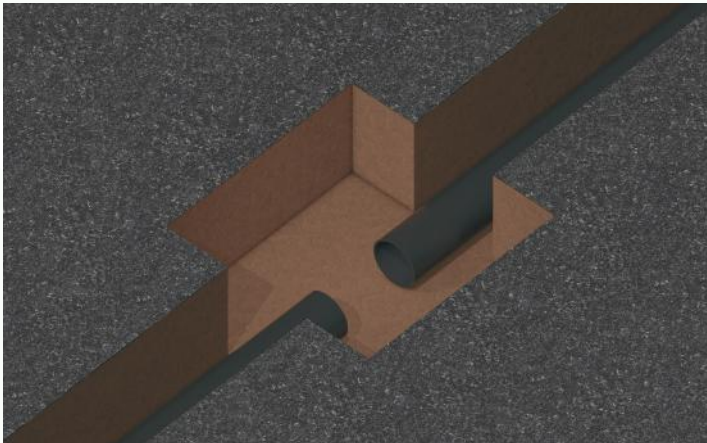



STEP 1 - PREP AND EXCAVATE AREA

1. Mark the location in which the EV Block will be installed (survey as required).
2. Excavate to the lines and grades shown on the construction drawings. Excavation may be completed using auger drilling or typical open-cut excavation. Care should be used to minimize over-excavation (unless required) or disturbance of the surrounding soils.
3. Excavation limits should extend a minimum of 4 to 6 inches (10cm to 15cm) beyond the edges of the EV Block unit.
4. The bottom limits of the excavation should extend at least 6 inches (15cm) beyond the height of the EV Block unit or local frost depth requirement, whichever is greater. The bottom limits should be well compacted and flat to allow for installation of at least a 6-inch-thick (15cm) crushed stone foundation. Greater amounts of crushed stone will be needed in areas where over-excavation to meet local frost depth requirements is required. The crushed stone foundation shall be compacted so as to provide a smooth, hard surface on which to place the EV Block unit.

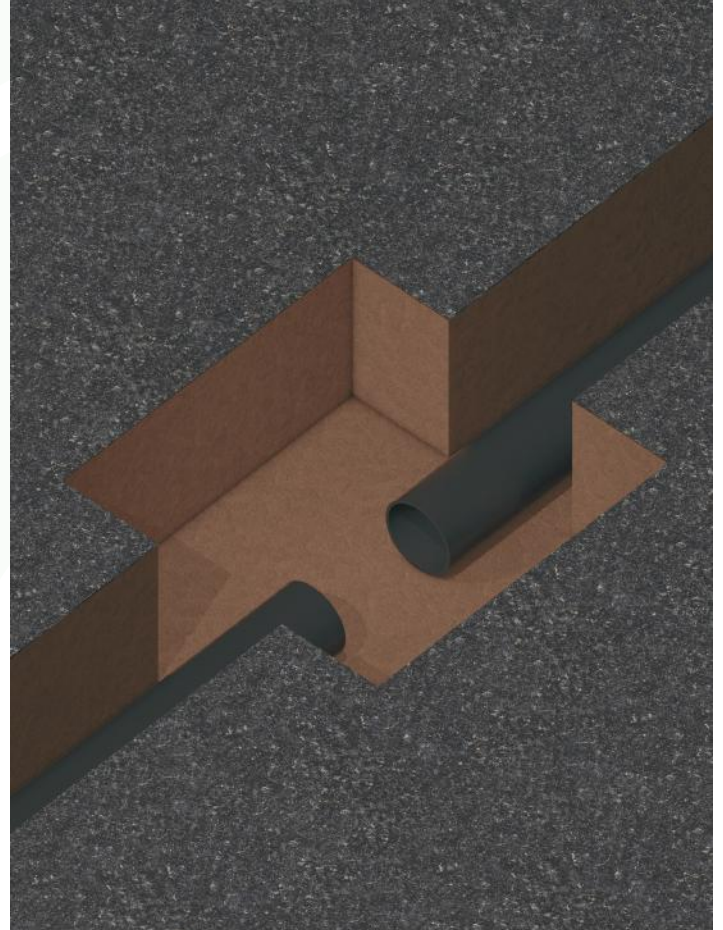
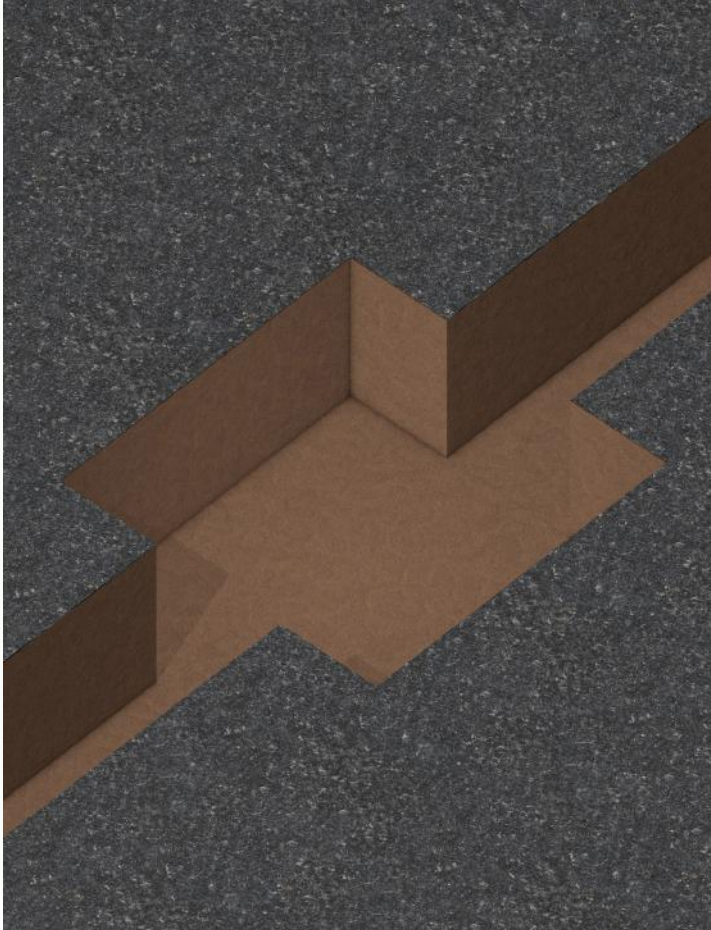



STEP 2 – PLACE THE EV BLOCK AND INSTALL CONDUIT

1. Lift the EV Block unit by using the double basket method with two nylon straps set 90 degrees opposite of each other and placed within the U-shaped openings in the sides. Nylon straps used shall be properly rated to adequately support the weight of the EV Block unit.
2. Lower the EV Block unit into the excavated hole ensuring that the side openings are properly aligned for the site and installation requirements.
3. Once the EV Block unit is in place, ensure that it is level in both directions and that the upper surface elevation is set to the project requirements within +/- 1/2-inch (1.25cm).
4. Brace the EV Block unit as required to maintain the location and level until the unit can be backfilled.
5. Once all of the conduit is installed via the side openings backfill the EV Block unit using either crushed stone or granular backfill. Either backfill material used shall be placed in maximum 6-inch lifts (15cm). If granular backfill is used, the material shall be compacted to 95% Standard Proctor density determined in accordance with ASTM D698. Backfill material shall be placed to an elevation as shown in the Project Plans accounting for any paving or landscaping material that is to be installed around the unit.
6. Install the required paving or landscaping material around the EV Block unit as shown in the Project Plans.



Note - The EV Block **must** be level in both directions

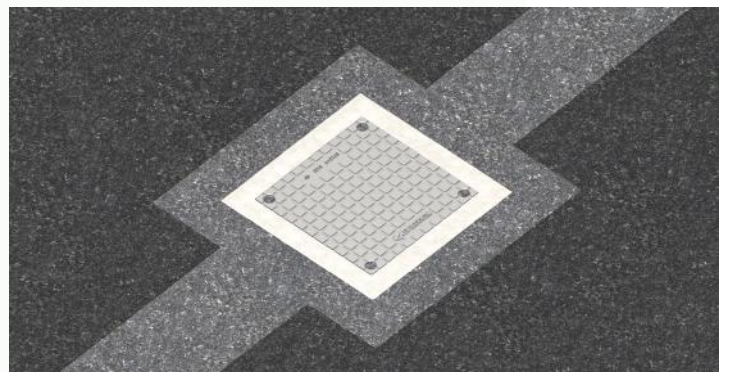



STEP 3 – MOUNT CHARGER PEDESTAL AND INSTALL ADAPTOR PLATE

1. If not removed already, remove the adaptor plate from the top of the EV Block by removing the bolts in the corners. Note that the supplied bolts require a specific driver bit that fits into the tamper-resistant head.
2. Obtain a pedestal bolting diagram from the EV charger manufacturer. If a bolting diagram cannot be obtained, the actual pedestal may be used.
3. Secure the bolting diagram to the bottom side of the Adaptor Plate ensuring that it is properly centered and aligned on the plate.
4. Transfer the pedestal bolting locations to the Adaptor Plate using a marker pen or other marking device.
5. Remove the bolting diagram and drill holes through the Adaptor Plate at the marked locations. The diameter of the hole may vary but should be large enough to accommodate the required bolting hardware for securing the EV charger pedestal. At the same time use a hole saw to cut a hole big enough for your cables to enter the charger.

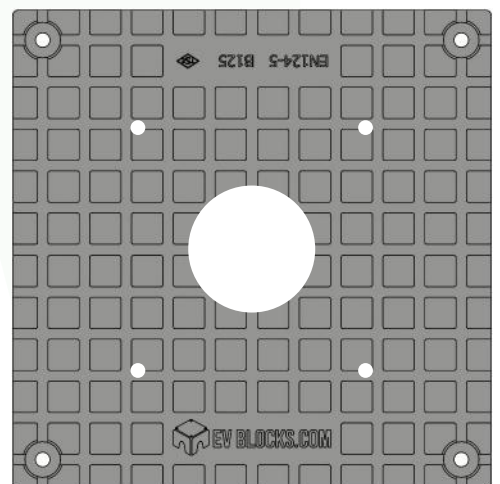
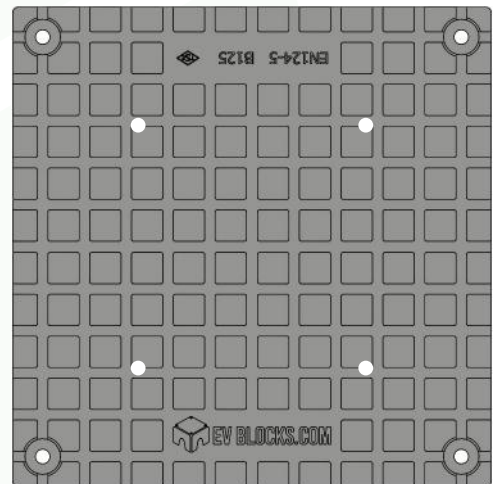
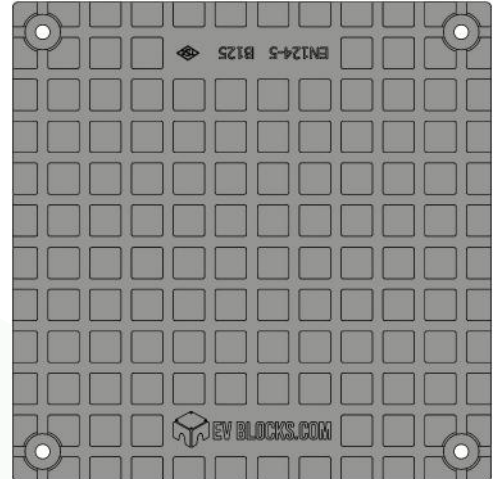



STEP 3 – MOUNT CHARGER PEDESTAL AND INSTALL ADAPTOR PLATE CONTINUED

6. Secure the EV charger pedestal to the Adaptor Plate using stainless steel bolts, nuts and washers. It is recommended that stainless steel lock nuts are used but are not required.
7. Place the Adaptor Plate and pedestal back onto the EV Block unit and secure the Adaptor Plate using the supplied bolts and washers.
8. Complete the required wiring for the EV charger. Refer to the EV charger manufacturer's instructions for any wiring requirements.

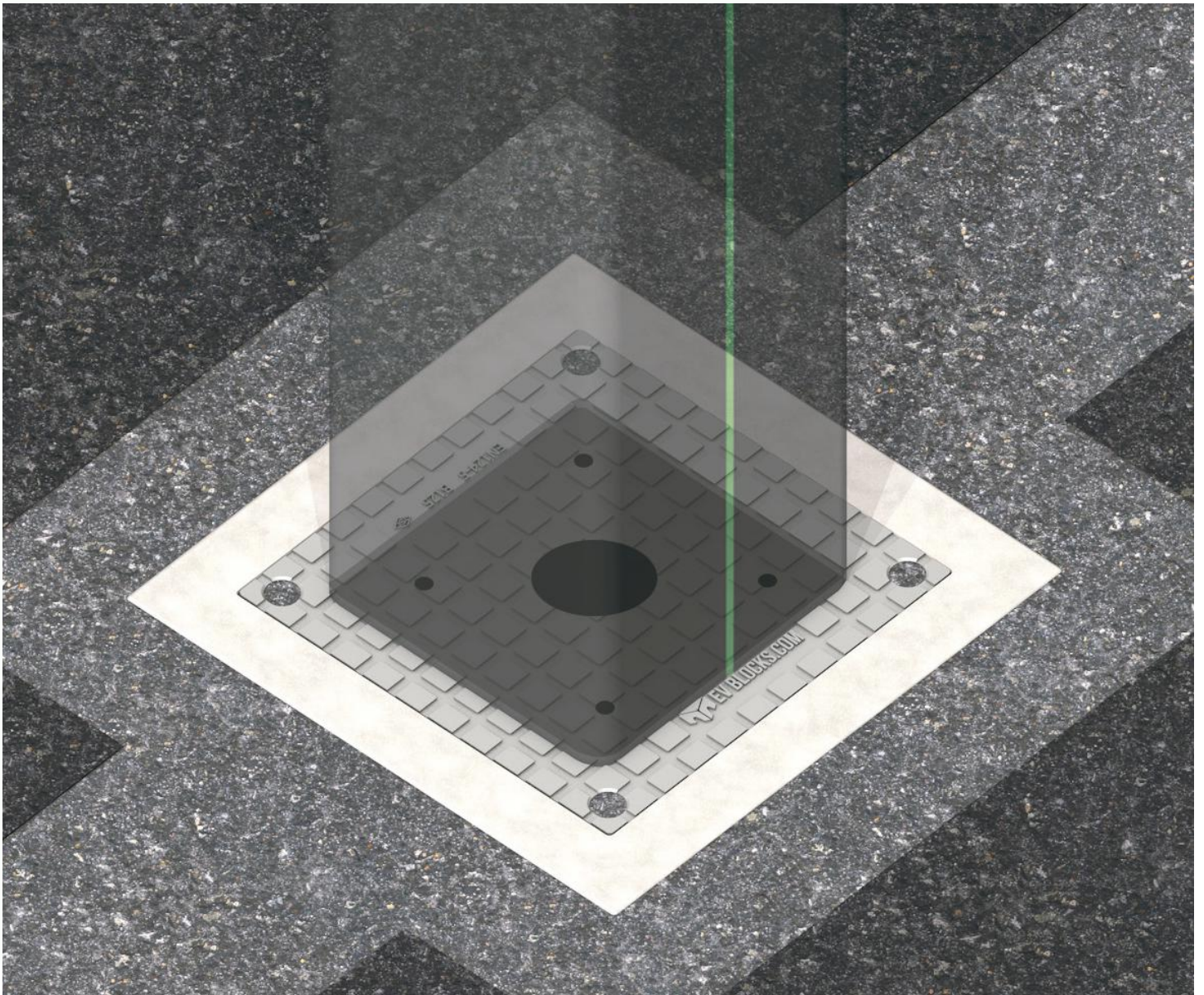



ITEM:	QUANTITY:	SPECIFICATION:
CONCRETE	0.17 CUBIC YARDS	MIN. 4,000 PSI @ 28 DAYS
ADAPTOR PLATE	1	COMPOSITE MATERIAL, ANSI TIER 15 RATED, SLIP RESISTANT SURFACE
EMBEDDED ANCHORS	4	1/2" x 2 1/2" PLASTIC NC THREADED INSERT
SECURING SCREWS	4	1/2"-13 x 3" STAINLESS STEEL, TAMPER RESISTANT, BUTTON HEAD

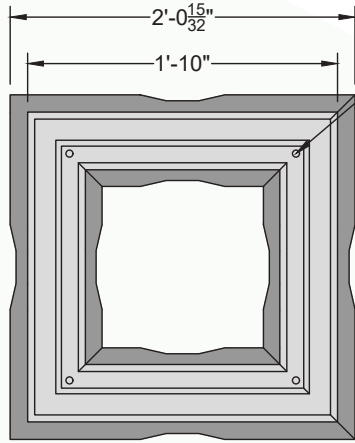

PRODUCT TOP VIEW

1" = 1'-0"

EMBEDDED ANCHOR POINT (4 THUS)

APPROX. BOLTING AREA = 13" x 13"

SECURING SCREW LOCATION (4 THUS)

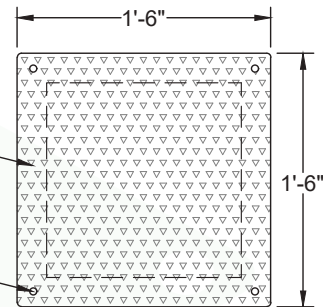

ADAPTOR PLATE DETAIL

1" = 1'-0"

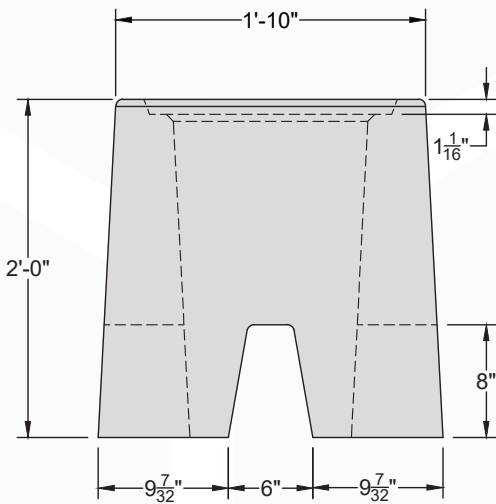

PRODUCT SIDE VIEW

1" = 1'-0"

APPROX. WEIGHT 650 LBS.

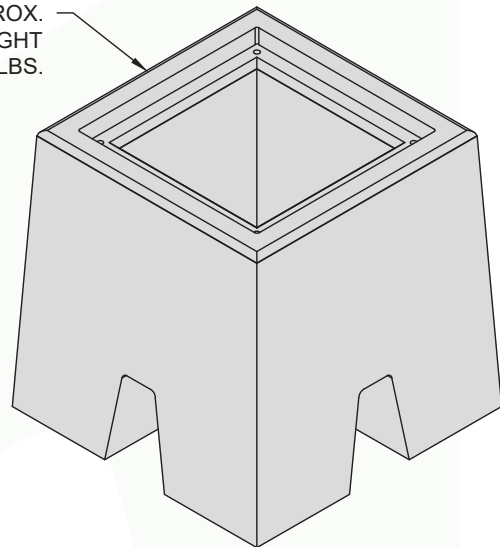

PRODUCT ISO VIEW

NTS

Disclaimer: This drawing has been prepared by EV Blocks, Ltd. and to the best of its knowledge, accurately represents the product use in the application that it is illustrated. Anyone making use of this drawing does so at their own risk and assumes all liability for such use. Final design for construction purposes must be completed by a Registered Professional Engineer who is familiar with the product and who has taken into account specific site conditions.



STANDARD EV BLOCK

EV BLOCKS - NORTH AMERICA
612-474-0089
EVBLOCKS.COM/US



LIMITED PRODUCT WARRANTY

Each EV Block will have a 28-day compressive strength of at least 4,000 PSI (27.6 Mpa) for 15 years after proper installation. If an EV Block does not meet this warranty standard, please notify the manufacturer in writing. If it has been determined that the EV Block has not met the specifications, the manufacturer will have shipped to you a replacement EV Block, which shall be the manufacturer's sole remedy for breach of this warranty. However, neither the manufacturer nor EV Blocks Ltd. shall have any obligation to install such replacement EV Block.

This warranty shall not apply to any EV Block which is damaged, defective or fails to meet the warranty standard due to improper installation of the EV Block, chemical contact, or excessive and unforeseen site conditions beyond the manufacturer's or EV Blocks Ltd.'s control.

The above warranty is the exclusive limited product warranty. ALL OTHER WARRANTIES, EXPRESS OR IMPLIED, INCLUDING WARRANTIES OF MERCHANTABILITY OR FITNESS FOR A PARTICULAR PURPOSE, ARE DISCLAIMED.



EV BLOCKS.COM®



**ENGINEERED TO
SAVE YOU TIME
AND MONEY**

DISTRIBUTED BY:



USA@EVBLOCKS.COM

+1-612-474-0089

EV Blocks - N. America
11521 Eagle St NW, Suite 3
Coon Rapids, MN 55448 USA